



CW-7 CWO-1700-MG Circle Welder

Features:

- Welding control.
- Wire feeder with one set of drive rolls.
- DC drive motor and speed control for rotation.
- Meter kit with 0-50 DC volt meter, 0-500 DC amp meter.
- Gun and cable assembly.
- Burnback control.
- 50 ft. (15 m) control cable.
- Quick disconnects for welding lead.
- Weld switch.
- Cold wire inch switch.
- Wire direction switch.
- Torch angle adjustor.
- 60 lbs. (27 kg.) wire reel.
- Vertical and horizontal adjustment by rack and pinion.
- Rise and fall slide assembly with 7" (175 mm) of movement.

Technical Data:

CWO-1700-MG

- Current Rating:** 500 amps CO₂,
400 amps mixed gases
60% duty cycle
- Input Voltage:** 115 VAC (from welder)
- Wire Sizes:** Sub Arc, MIG: .035-3/32"
(0.8-2.4 mm)
- Rise and Fall Cam:** 0-7" (0-175 mm)
- Rotation Speed:** .2-2.2 rpm (100-3500 mm/min)
- Welding Diameter:** Standard 6-24" (150-600 mm)
Optional 10-50" (254-1270 mm)
- Height:** 34" (864 mm)
- Net Weight:** 250 lbs. (113.6 kg)

The CW-7 may be used with any constant voltage power source with connections for 115 VAC and weld contactor.

- Options:**
Horizontal and vertical adjustment may be motorized.
- Oscillator when gas option is on machine.
- Sub-Arc components available.

Racking System for 10-50 inch (254-1270 mm) diameter available.

Optional 10-50 inch (254-1270 mm) welding diameter is available.

FRONT ELEVATION

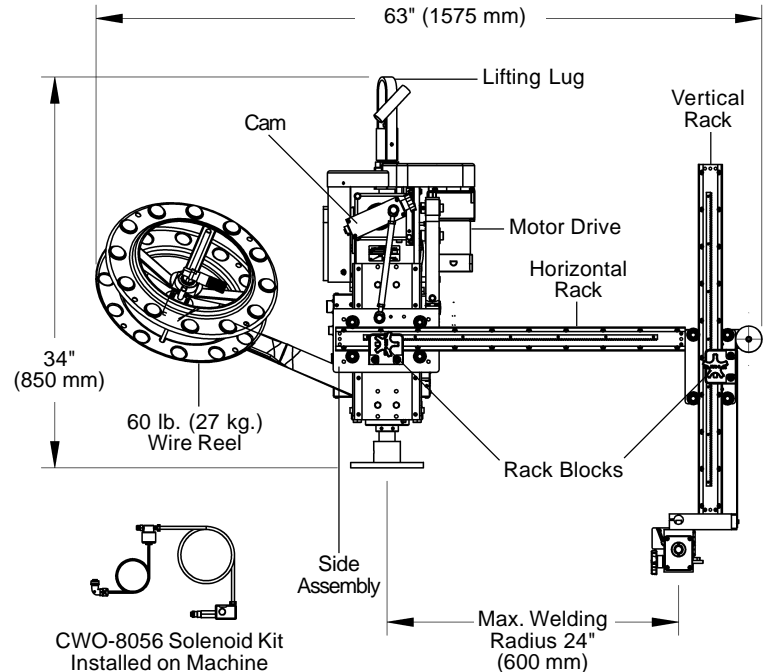

SIDE ELEVATION

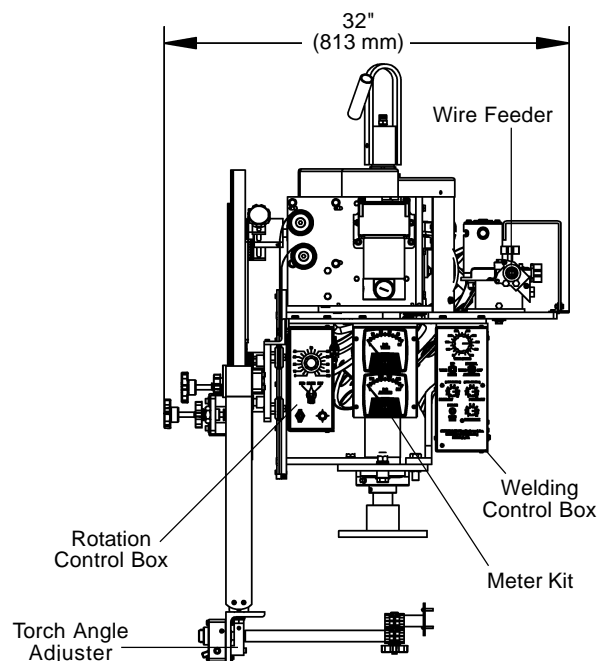



CW-7 CWO-1700-SA Circle Welder

Features:

- Welding control.
- Wire feeder with one set of drive rolls.
- DC drive motor and speed control for rotation.
- Meter kit with 0-50 DC volt meter, 0-500 DC amp meter.
- Gun and cable assembly.
- Nozzle flux cone.
- Burnback control.
- 50 ft. (15 m) control cable.
- Quick disconnects for welding lead.
- Weld switch.
- Cold wire inch switch.
- Wire direction switch.
- Torch angle adjustor.
- Flux hopper with gate valve.
- 60 lbs. (27 kg.) wire reel.
- Vertical and horizontal adjustment by rack and pinion.
- Rise and fall slide assembly with 7" (175 mm) of movement.

Technical Data:

CWO-1700-SA

- Current Rating:** 500 amps CO₂,
400 amps mixed gases
60% duty cycle
- Input Voltage:** 115 VAC (from welder)
- Wire Sizes:** Sub Arc, MIG: .035-3/32"
(0.8-2.4 mm)
- Rise and Fall Cam:** 0-7" (0-175 mm)
- Rotation Speed:** .2-2.2 rpm (100-3500 mm/min)
- Welding Diameter:** Standard 6-24" (150-600 mm)
Optional 10-50" (254-1270 mm)
- Height:** 34" (864 mm)
- Net Weight:** 250 lbs. (113.6 kg)

The CW-7 may be used with any constant voltage power source with connections for 115 VAC and weld contactor.

Options:

Horizontal and vertical adjustment may be motorized.

Gas option for MIG and flux cored welding is available.

Flux Recovery System.

Optional Racking for 10-50 inch (254-1270 mm) diameter available.

Optional 10-50 inch (254-1270 mm) welding diameter is available.

FRONT ELEVATION

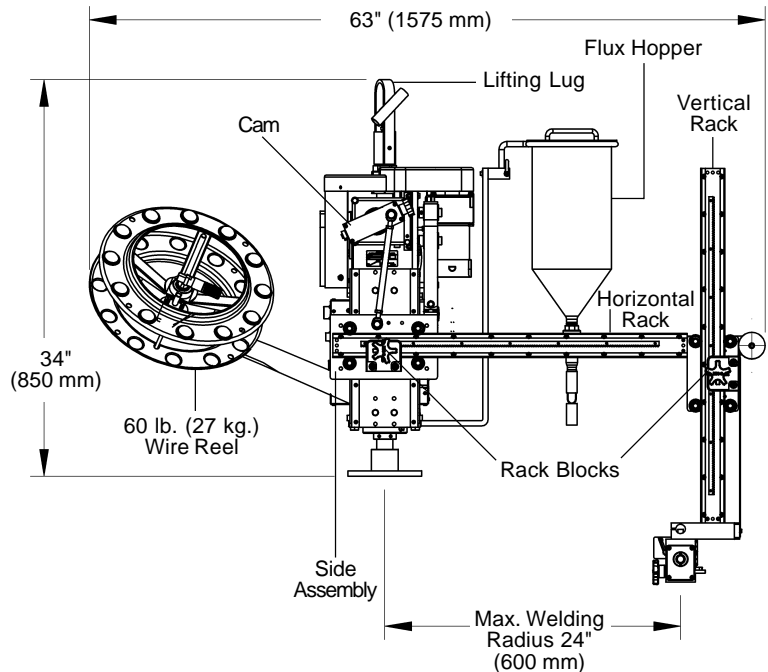

SIDE ELEVATION

